



EXPERIENCE WITH DETECTION AND IDENTIFICATION OF WINDING BUCKLING IN POWER TRANSFORMERS

Victor V. Sokolov and Boris V. Vanin
ZTZ-Service Company

ABSTRACT

The paper summarizes experience with identification of buckling of inner windings using leakage reactance matrix of changes. The diagnostic threshold values are suggested. The case studies of units with different designs are discussed.

INTRODUCTION

The failures of large power transformers, caused by winding movement, are due to the effects of short circuit stresses and comprise 12-15% of total failures [1,2]. Many of mechanical-mode failures have occurred due to the radial buckling of the inner winding. Experience also shows that a transformer with the partially deformed windings can remain in service for a long time, however, the reliability of such a unit is reduced [3].

Winding deformation is an irreversible fault, and the replacement of the damaged winding may be the only remedy. A cost of repair could be comparable with the price of a new unit. Therefore, in order to decide on how to proceed with a questionable transformer, the following questions have to be answered first.

- Is the transformer really damaged?
- Is it possible to continue its operation?
- If yes, then for how long, and under what conditions?

Although it is important to have a sensitive diagnostic tool that detects winding deformation, it is also important to have a reliable diagnostic approach that could identify fault location and perform quantitative analysis of the winding movement.

A variety of techniques is being used to detect winding deformation in transformers [4]:

- winding capacitance
- leakage reactance (LR)/leakage impedance
- low voltage impulses (LVI)
- frequency response analysis (FRA) using the impulse method or the swept frequency method
- frequency response of leakage impedance
- frequency response of stray losses.

Each technique has advantages and disadvantages. To make a proper conclusion about the condition of a critical transformer advantages of different techniques have to be utilized. FRA [5] has been recognized [4] as the most sensitive technique to detect a minor winding movement. This method is claimed to allow detection of most possible modes of winding distortion: radial, axial and twisting as well the change in the clamping pressure. However, FRA still leaves uncertainties in the quantitative interpretation, in a fault location, as well as the uncertainty as to what is actually being detected: movement of the windings or change in the clamping pressure. On the other hand, it was reported [6] that LR provides a very reliable indication of winding deformation, especially if a benchmark value is available. Furthermore, this is a rather simple technique that requires relatively standard equipment. Significance and application of this technique is discussed in detail in [7 - 9]. However, the following disadvantages of the LR have been emphasized [4]:

- Very small changes in LR, on the order of 1%, have to be detected.
- In some cases, it is difficult to obtain a reliable indication of windings condition if no reference results are available.

ZTZ-Service Company has accumulated over 15 years of experience with LR technique. This experience has shown the following:

- the LR measurement is an extremely reliable tool for detection and identification of winding buckling
- some of the limitations, described above, could be mitigated by utilizing a non-traditional approach to interpretation of the test data [10].

The objective of this paper is to discuss the physical aspects of winding buckling, its interpretation through the LR data, suggested diagnostic criteria, and experience with detection and identification of defective condition of core-form transformers.

BASICS OF WINDING BUCKLING

During the overcurrent conditions, the radial electromagnetic forces create a significant compressive stress around the turns of a winding. This causes conductors of the turns to buckle inwards between the two or three adjacent sets of supporting sticks. The buckling creates stretching in the rest of the turn. The stretching and radial reaction of the inner turns impede the further buckling. Presence of the buckled segment changes the coupling of the leakage flux to the coil. At the same time, the inner turns retain some of the shortage in their length, which makes the coil diameter less than it was before buckling. All this results in the change of leakage reactance. Thus, the relative change in leakage reactance can serve as an indication of the radial buckling of the winding.

Leakage reactance in % is expressed by the well-known Rogowsky formula:

$$e = \frac{24.8 \cdot I_r \cdot W \cdot \rho \cdot \Sigma RD}{E \cdot H \cdot 10^4} \quad (1)$$

where ΣRD in cm^2 is defined as follows (see Figure 1)

$$\Sigma RD = \frac{b_1 \cdot R_1}{3} + c R_{12} + \frac{b_2 \cdot R_2}{3} \quad (2)$$

I_r is the rated current

W is the number of turns

E is the volts-per-turn

ρ -Rogovsky coefficient

$H = (H_1 + H_2)/2$ is the average height of the windings.

The relative change in leakage reactance can be expressed as:

$$\varepsilon = (X^1 - X)/X \approx G(\Delta x) \quad (3)$$

Where:

X is the initial measured value of leakage reactance

X^1 is the subsequent measured leakage reactance

Δx is the change in the coil average radius

G is the design parameter defined as follows:

$$G = [R_{12} - (b_1/3) - (c/2)]/(\Sigma RD)$$

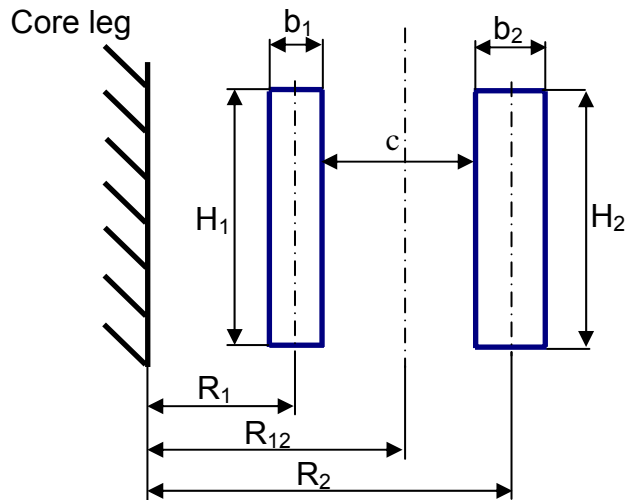

Geometrical Parameters of Windings
Figure 1

DIAGNOSTICS OF WINDING BUCKLING

Criteria for Buckling Detection

Three-winding transformer or autotransformer with tertiary

The buckling of the inner winding caused by the over-current conditions is found in:

- common winding
- tertiary (or low-voltage) winding

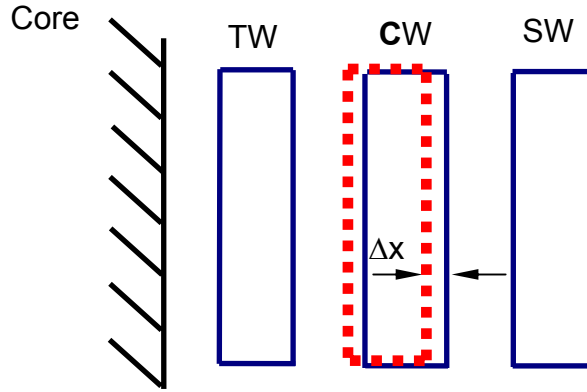

Model of Common Winding (CW) Buckling
 TW – Tertiary Winding, SW – Series Winding
 Figure 2

In case of a common winding buckling, the following criteria is used:

$$\varepsilon_{\text{CW-TW}} \approx \frac{G_{\text{CW-TW}}}{(\Delta x)} \quad \varepsilon_{\text{SW-CW}} \approx - \frac{G_{\text{SW-CW}}}{(\Delta x)} \quad \varepsilon_{\text{SW-TW}} \approx 0 \quad \varepsilon_{\text{CW-TW}}/\varepsilon_{\text{SW-CW}} \approx \text{const} \quad (4)$$

Therefore, the buckling associated with the common winding can be identified by a relative change in LR having different signs for leakage channels CT-TW and SW-CW. The inequality of $\varepsilon_{\text{SW-TW}}$ exactly to zero and variation of the ratio $\varepsilon_{\text{CW-TW}}/\varepsilon_{\text{SW-CW}}$ is a characteristic of the presence and the size of the measurement error.

In case of a tertiary winding buckling, the following criteria is used:

$$\varepsilon_{\text{TW-CW}} \approx \frac{G_{\text{TW-CW}}}{(\Delta x)} \quad \varepsilon_{\text{TW-SW}} \approx \frac{G_{\text{TW-SW}}}{(\Delta x)} \quad \varepsilon_{\text{CW-SW}} \approx 0 \quad \varepsilon_{\text{TW-CW}}/\varepsilon_{\text{TW-SW}} \approx \text{const} \quad (5)$$

Therefore, the buckling associated with the tertiary winding can be identified by a relative change in LR having the same sign for leakage channels TW-CW and TW-SW. The inequality of $\varepsilon_{\text{CW-SW}}$ exactly to zero and variation of the ratio $\varepsilon_{\text{TW-CW}}/\varepsilon_{\text{TW-SW}}$ is a characteristic of the presence and the size of the measurement error.

The described criteria are applied to each per-phase test. The same approach can be used for three-winding transformers.

Two- and three-winding transformers

The following discussion describes criteria for two- and three-winding transformers:

$$\varepsilon_A = (X_A^1 - X_A)/X_A \approx G_A(\Delta X_A) \quad (6)$$

$$\varepsilon_B = (X_B^1 - X_B)/X_B \approx G_B(\Delta X_B) \quad (7)$$

$$\varepsilon_C = (X_C^1 - X_C)/X_C \approx G_C(\Delta X_C) \quad (8)$$

The relative change of LR can be presented consisting of two components. The first one representing the true deformation and the second, the measurement error:

$$\varepsilon_A = \varepsilon_{dA} + \varepsilon_{eA} \quad (9)$$

$$\varepsilon_B = \varepsilon_{dB} + \varepsilon_{eB} \quad (10)$$

$$\varepsilon_C = \varepsilon_{dC} + \varepsilon_{eC} \quad (11)$$

Given equations (9-11) and expecting that the measurement error is less than 2%, the following cases can be identified. All criteria assume that the results are compared with a credible benchmark.

a) Defect-free condition

In this case, the changes in LR are caused by the measurement errors only. Therefore,

$$\varepsilon_{dA} = \varepsilon_{dB} = \varepsilon_{dC} = 0 \quad (12)$$

and

$$|\varepsilon_{eA}| = \varepsilon_A < 2\% \quad (13)$$

$$|\varepsilon_{eB}| = \varepsilon_B < 2\% \quad (14)$$

$$|\varepsilon_{eC}| = \varepsilon_C < 2\% \quad (15)$$

b) All three phases are buckled

In this case, the criteria are as follows:

$$\varepsilon_A > 2\% \quad (16)$$

$$\varepsilon_B > 2\% \quad (17)$$

$$\varepsilon_C > 2\% \quad (18)$$

3) One of the phases is buckled

If the buckling is present in phase A, the criteria are as follows:

$$\varepsilon_A > 2\% \quad (19)$$

$$\varepsilon_B < 2\% \quad (20)$$

$$\varepsilon_C < 2\% \quad (21)$$

4) Incorrect measurement

One, two or all three per-phase ε are negative

Quantification of Deformation

In most cases, we find it useful to follow the following guidelines to categorize the extend of deformation:

- **Green zone** - allows for minor elastic displacements caused by moderate fluctuations in temperature and electromagnetic stress; for large power transformers this zone, typically, corresponds to $\Delta x \leq 5$ mm.
- **Yellow zone** – is characterized by a noticeable buckling; for large power transformers this zone, typically, corresponds to $5 \text{ mm} \leq \Delta x \leq 10$ mm.
- **Red zone** – is characterized by a critical buckling; for large power transformers this zone, typically, corresponds to $\Delta x > 10$ mm.

Using geometrical parameters defined in Figure 1, the simplified model of winding deformation in Figure 2, and equations (1 – 3), the diagnostic charts presented on Figure 3 could be developed for various transformer designs following the following steps:

- assume a winding deformation Δx
- adjust parameters on Figure 1 that are affected by Δx
- calculate new ΣRD using equation (2)
- calculate new leakage reactance “e” using equation (1)
- calculate a relative change in leakage reactance ε using equation (3)
- repeat the above steps for a new value of Δx
- plot $\varepsilon = f(\Delta x)$ using the two calculated data points

- perform this procedure for each leakage channel (in case of a multi-winding unit)

Figure 3 presents such a chart for a 250 MVA autotransformer with the tertiary. Once the chart is developed, the relative change in LR can be easily related to the geometrical displacement and corresponding diagnostic “traffic light” zone.

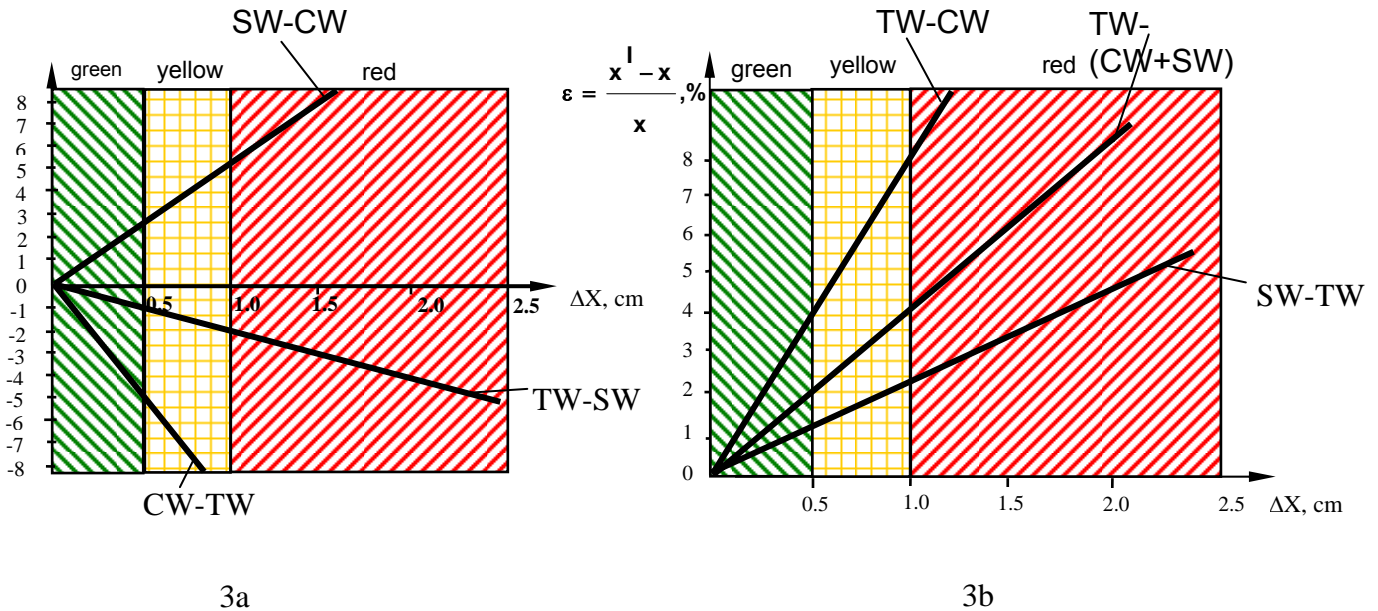

Three-State “Traffic Light” Deformation Chart for 250 MVA, 330/150/35 kV autotransformer

3a – Common Winding (CW) buckling

3b – Tertiary Winding (TW) buckling

CW+SW represents a HV winding

Figure 3

Effect of Windings Arrangement

Different designs and arrangements of windings produce different slopes of deformation traces. This results in the same deformation Δx producing different changes in relative LR. Typical examples are presented in Figures 4 - 6. Figure 4 shows that as the width of the leakage channel increases with the transformer voltage rating (i.e., from 110 kV to 400 kV), the sensitivity of LR to the inner winding buckling decreases. Figure 5 illustrates the change in sensitivity as the design changes from a split high-voltage winding to a split low-voltage winding. Figure 6 shows how the LR sensitivity to buckling of the tertiary winding decreases with the decrease of the voltage class of the common winding (i.e., from 150 kV to 110 kV).

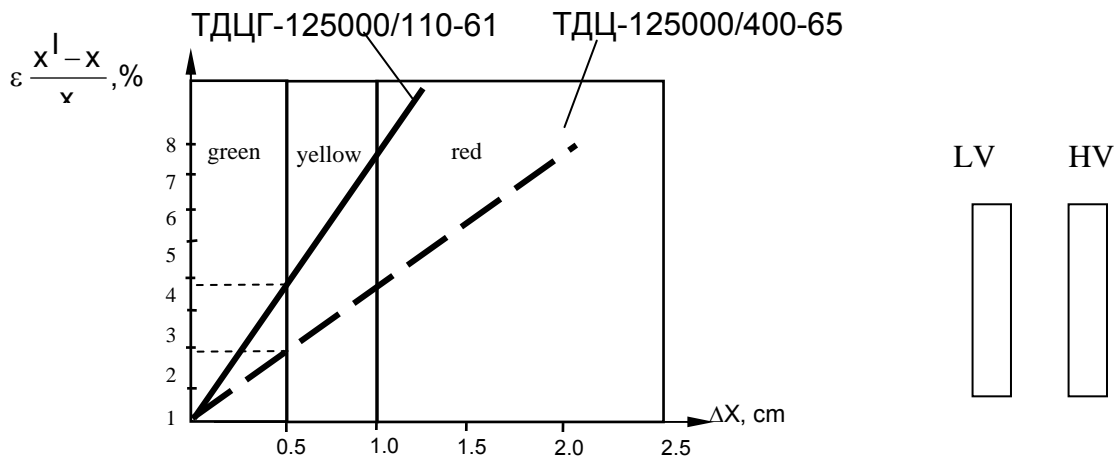

Two-Winding Unit: Influence of Rated Voltage on Sensitivity of LR to buckling
Figure 4

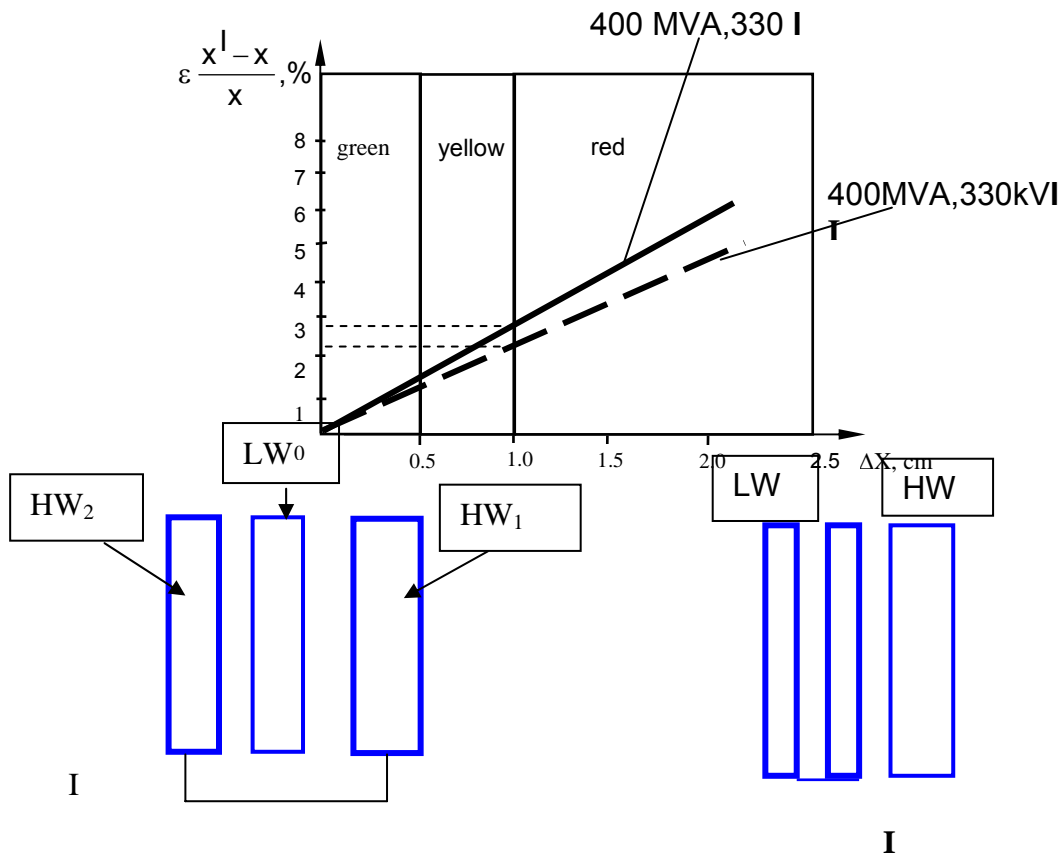

Influence of Winding Arrangement on LR sensitivity
Figure 5

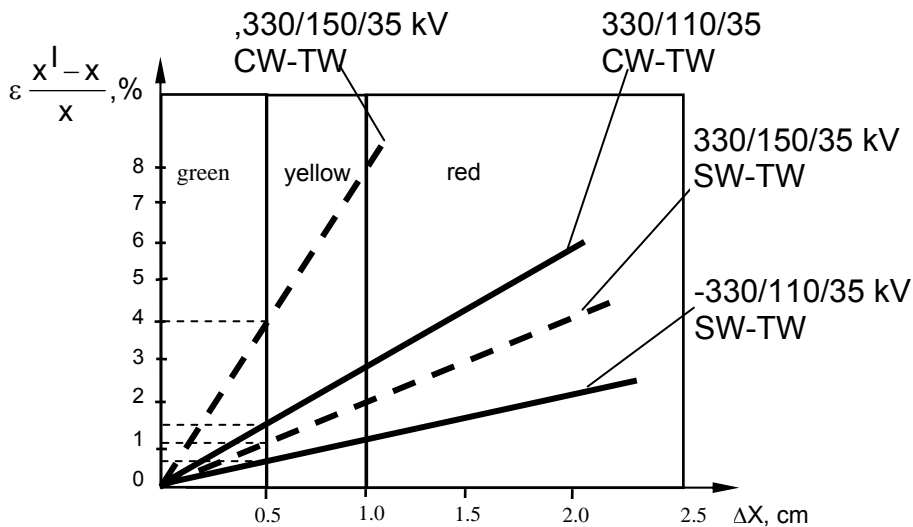

Autotransformer with Tertiary (250 MVA): Influence of Rated Voltage of Common Winding on Sensitivity of Buckling of Tertiary Winding
Figure 6

Testing Methodology

ZTZ-Service utilizes the following methods:

- A per-phase test using the three-phase excitation (typically 380 V). The instrument is a simple arrangement consisting of voltmeter, ammeter, wattmeter, and frequency meter.
- A per-phase test using the single-phase excitation with M4110 Doble Analyzer.
- Typically, the test voltage is applied to high- and medium-voltage windings.
- The copper short-circuiting cables have a cross-section that is not less than 30% of the winding conductor cross-section. A special attention is paid to minimizing the length of the cable and to the proper contact with transformer terminals.
- The nameplate data is typically presented as a short-circuit voltage u_{shc} %. It is more convenient to present LR in Ohms using equation:

$$X_s \cong Z_s = \frac{u_{shc} \cdot U_p}{100 \cdot I_p}, \text{ Ohm}$$

where U_p and I_p are the rated phase voltage and current.

To compare the results obtained using three-phase and single-phase excitation [9] and to compare different instruments a special comparative tests were performed. Tables I and II show that results obtained using single-phase excitation (with M4110) and results obtained using the three-phase excitation (with IMT) compare very closely to each other and to the nameplate value.

TABLE I

Comparative Tests of Leakage Impedance Using Different Test Instruments

Unit tested: 250 MVA, 330/150 kV

Test	Phase	M4110 single-phase Zs [Ohm]	IMT three-phase Zs [Ohm]
CW-HW	A	41.755	41.58
	B	41.775	41.63
	C	41.885	42.0

TABLE II

Comparison with Nameplate

Nameplate Zs [Ohm]	Phase	M4110 ΔZ_s [%]	IMT ΔZ_s [%]
41.56	A	0.47	0.05
	B	0.52	0.17
	C	0.78	1.05

Experience accumulated over the years at the ZTZ-Service Company is used to perform the assessment of mechanical condition of power transformers. This program includes the following:

- design review that involves estimation of the mechanical safety margin of windings,
- assessment of electromagnetic stresses in real operating condition including transformer history, fault current events, etc.,
- assessment of winding clamping forces by means of vibro-acoustic technology,
- LR test program considering the transformer design,
- assessment of winding buckling through LR test data.

During the period of 1984-2000, the ZTZ-Service methodology was used to identify over 40 transformers with mechanically deformed windings. Some of these cases are presented in the following sections. In all cases, the nameplate value was used as the benchmark. Once the benchmark with M4110 is obtained, much ambiguity is removed and reliability of conclusions increases.

Case Studies

Case #1: Buckling of one phase in the common winding of 250 MVA, 330/150/35 kV autotransformer

LR measurement was performed after a severe single-phase short circuit event on the 150-kV side. Test results presented in Table III indicate a critical condition (**Red Zone**) in the phase A of the common winding. Note that in addition to ϵ for CW-TW and (CW+SW)-CW having the opposite signs, the ϵ for CW-TW has the same sign but is higher than ϵ for (CW+SW)- TW.

Table III

Test circuit	Phase	Xs Measure d [Ohm]	Zs Nameplate [Ohm]	Comparison with NP ϵ [%]	Comparison between phases ϵ [%]	ϵ [%] corresponding to $\Delta x = 10$ mm
CW-TW	A	39.98	41.74	-4.22	5.24	-4.5
	B	41.40		-0.80		
	C	42.19		1.06		
(CW+SW)-CW	A	46.62	44.46	4.87	2.99	+4
	B	45.54		2.44		
	C	45.23		1.73		
(CW+SW)- TW	A	226.45	231.88	-2.34	3.53	-2
	B	229.77		-0.91		
	C	234.74		1.23		

The internal inspection confirmed the presence of deformation (Figure 7). The unit was left in operation as a “hot” reserve unit under a frequent DGA monitoring. The subsequent measurement a year later has not revealed any changes in the condition of the unit.

Common winding

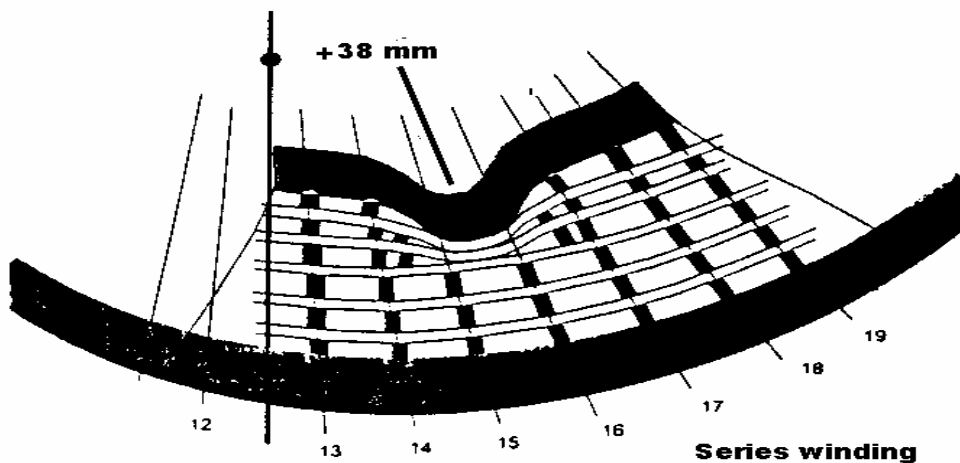

Sketch of the Common Winding of 250 MVA Autotransformer buckling
Figure 7

Case #2: Buckling of one phase in the common winding of 200 MVA, 330/110/35 kV autotransformer with LTC on 110 kV side

This unit was tested using M4110 as part of the condition assessment program after the 34 years of service. Test data is presented in Table IV.

TABLE IV

Test circuit	Phase	Xs Measure d [Ohm]	Zs Nameplate [Ohm]	Comparison with NP ϵ [%]	Comparison between phases ϵ [%]	ϵ [%] corresponding to $\Delta x = 10$ mm
CW-TW	A	13.54	14.54	-6.87	5.39	-6
	B	14.24		-2.06		
	C	14.27		-1.85		
(CW+SW)-CW	A	56.11	53.89	4.12	4.12	+4.1

	B	54.41		0.96		
	C	53.89		0		
(CW+SW)- TW	A	174.45	179.64	-2.9	3.05	- 2.3
	B	179.73		0.05		
	C	178.89		-0.42		

Critical buckling of the phase A of the common winding (**Red Zone**) was suspected. An internal inspection confirmed the problem revealing one wave of deformation (Figure 7).



Top view on the common winding buckling in 200 MVA autotransformer
Figure 8

Case #3: Buckling of two phases in the tertiary winding of 125 MVA, 330/110/10.5 kV autotransformer with LTC on 110 kV side

This unit was tested using M4110 as part of the condition assessment program after the 29 years of service. Test data is presented in Table V.

TABLE V

Test circuit	Phase	Xs Measured [Ohm]	Zs Nameplate [Ohm]	Comparison with NP ϵ [%]	Comparison between phases ϵ [%]	ϵ [%] corresponding to $\Delta x = 10$ mm
CW-TW	A	23.92	22.88	4.48	5.24	4.5
	B	23.38		3.01		
	C	24.04		4.48		
(CW+SW)-CW	A	82.48	82.61	-1.28	0	0
	B	82.48		-1.28		
	C	82.48		-1.28		
(CW+SW)- TW	A	292.68	283.22	3.34	1.92	3
	B	287		1.35		
	C	290.8		2.67		

The buckling of phases A and C in the tertiary winding was suspected (**Yellow Zone**). The distance between the TW winding and the core was fairly small. However, considering the low power factor value of the space “TW - Core” (0.44% at 50°C), the unit was left in operation with the recommendation to repeat the LR test after one year or, in case of a through-fault, right after that event.

Case #4: Buckling of one phase in the tertiary winding of 250 MVA, 330/150/35 kV autotransformer without LTC

This unit was tested using M4110 as part of the condition assessment program triggered by the many through-fault events seen by the unit during the 18 years of service. Test data is presented in Table VI.

TABLE VI

Test circuit	Phase	Xs Measured [Ohm]	Zs Nameplate [Ohm]	Comparison with NP ϵ [%]	Comparison between phases ϵ [%]	ϵ [%] corresponding to $\Delta x = 10$ mm
CW-TW	A	22.66	22.10	2.53	3.54	6.4
	B	23.39		5.83		
	C	22.59		2.22		
(CW+SW)-CW	A	47.7	49.98	1.5	0	0
	B	48.2		2.6		
	C	48.01		2.2		
(CW+SW)-TW	A	147.85	144.85	2.1	2.5	4
	B	150.87		4.1		
	C	147.19		1.6		
SW- TW	A	75.14	73.92	1.65	1.77	2.4
	B	76.47		3.45		
	C	75.17		1.69		

A critical buckling of the phase B in the tertiary winding was suggested. Considering low power factor value of the space “TW - Core”, the unit was left in service as a “hot” reserve.

Case #5: Buckling of two phases in the tertiary winding of 250 MVA, 330/150/35 kV autotransformer without LTC

This unit was tested using M4110 as part of the condition assessment program after 12 years in service. The program was triggered by the many through-fault events on the 35-kV side due to contamination of external insulation and the presence of large rotating machinery causing high load current fluctuations. Test data is presented in Table VII.

TABLE VII

Test circuit	Phase	Xs Measured [Ohm]	Zs Nameplate [Ohm]	Comparison with NP ϵ [%]	Comparison between phases ϵ [%]	ϵ [%] corresponding to $\Delta x = 10$ mm
CW-TW	A	24.33	23	2.53	3.54	6.4
	B	22.85		5.83		
	C	24.51		2.22		
(CW+SW)-CW	A	47.3	47.41	-0.23	1.03	0
	B	47.89		1.01		
	C	47.43		0.04		
(CW+SW)-TW	A	154.6	150.07	5.91	7.28	4

	B	149.96		-0.53		
	C	156.39		6.7		

A critical buckling of phases A and C in the tertiary winding was suspected (**Red Zone**). Comparing the measured phase-to-ground capacitance values with the calculated values confirmed the problem. The measured data was as follows: phase A - 2345 pF, phase B - 2620 pF, and phase C - 2280 pF. During the internal inspection the following was found:

- a very loose clamping of the TW winding
- distortion of insulation between TW and CW in the phase C
- presence of two waves of deformation in the phase A of the TW winding.

Case #6: Buckling of the inner high-voltage winding in 400 MVA, 347/20 kV generator step-up transformer.

After an asynchronous generator switching, a gas was detected in the transformer gas relay. The DGA analysis showed clear symptoms of arcing (Table VIII). The subsequent oil analysis has shown decrease in the gas concentrations.

TABLE VIII
DGA Concentrations

GAS concentration, ppm				
H2	CH4	C2H4	C2H6	C2H2
245	30.5	35.3	5.1	245

The LR measurement was suggested to verify the mechanical state of windings. Test results are given in the Table IX.

TABLE XI

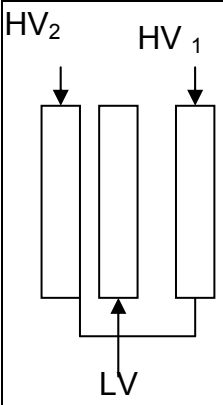
Winding arrangement	Test circuit	Phase	Leakage impedance [Ohm]		ϵ_{N-p-s}	ϵ^1	ϵ_{ABC}	Tests
			NP	Measure d				
	HV-LV	A	35.3	35.39	0.25	-	0.28	Initial test
		B		35.08	-0.62	-		
		C		35.39	0.25	-	0.28	
	HV-LV	A	35.3	36.23	2.63	2.37	3.28	Test after asynchronous switching
		B		35.08	-0.62	0		
		C		35.33	0.08	-0.16		

Given the design of this unit, only the buckling of the inner HV₂ winding could have been expected. Relative change of the leakage impedance in phase A increased by 2.63% relative to the nameplate value and by 2.37% relative to the per-phase test. However, the design review showed that due to the fact that the HV-winding is a split winding, the sensitivity of LR to the buckling of HV₂ winding is limited and Yellow Zone corresponds to the 2% of the relative change in LR. The difference between LR tested on different phases also pointed to defective condition of phase A. The unit was removed from operation. After disassembling the active part, the two waves of deformation were revealed in phase A of HV₂ winding. The traces of flash-over between the coils were found along the supporting sticks due to distortion of the leakage channel.

REFERENCES

1. Nilsson, S. and Lindgren, S., "Review of Generator Step-Up Transformer Failure Data". *Proceedings of the EPRI Substation Equipment Diagnostic Conference V*, February 1997.
2. Sokolov, V., "Transformer Life Management Considerations", *Proceedings of the 1997 CIGRE Regional Meeting*, Melbourne, Australia.
3. Sokolov, V. V., "Consideration on Power Transformer Condition- based Maintenance", *EPRI Substation Equipment Diagnostic Conference VIII*, February 20-23, 2000, New Orleans, LA.
4. Fyvie, J., Lindroth, A., Spoorenberg, K. and Lapworth, J., "The Short-Circuit Ability of Power Transformers Part 4: Winding movement detection techniques", *Report of Cigre WG 12.19 "Short Circuit Performance of Power Transformers"*.
5. Lapworth, J. A. and McGrail, A. J., "Transformer Winding Movement Detection by Frequency Response Analysis", *Proceedings of the Sixty-Six Annual International Conference of Doble Clients*, 1999, sec. 8.14.
6. Zafferani, G., "Transformer leakage reactance measurement as a diagnostic tool," *Proceedings of the sixty-seventh Annual International Conference of Doble Clients*, 2000.
7. Lachman, M. F., "Low-voltage single-phase leakage reactance measurement on transformers-significance and application, part I," *Minutes of the Sixty-First Annual International Conference of Doble Clients*, 1994, sec. 6.5.
8. Lachman, M. F., and Shafir, Y. N., "Low voltage single phase leakage reactance measurement on transformer-influence of magnetizing reactance," *Proceedings of the Sixty-Second Annual International Conference of Doble Clients*, 1995, sec. 8.12.
9. Lachman, M. F., and Shafir, Y. N., "Influence of single-phase excitation on transformer leakage reactance", *Proceedings of the Sixty-Second Annual International Conference of Doble Clients*, 1995, sec. 8.13.
10. Sokolov, V. V., et al., "Detection of winding deformation in large power transformers," (in Russian), *Electrical Stations*, Moscow, 1988, #6, pages 52-56.